

Weather and Sound Enclosures

Applicable to the following:

180- 450REZXB, 180- 400RZXB, and 300REZXC

Weather Enclosure Features

- Internal-mounted critical silencer with rain cap and flexible exhaust connector.
- Skid-mounted, steel construction with hinged doors.
- Fade-, scratch-, and corrosion-resistant Kohler® Power Armor™ automotive-grade textured finish.
- Enclosure has four (180- 250REZXB/RZXB and 300REZXC) or six (300- 400REZXB/RZXB and 450REZXB) large access doors which allow for easy maintenance.
- Lockable, flush-mounted door latches.
- Vertical air inlet and outlet hoods with 90 degree angles to redirect air and reduce noise.
- Automatic door holders keep doors open during maintenance.
- Steel weather enclosure is designed to 150 mph (241 kph) wind load rating.

Sound Enclosure Features

- Includes all of the weather enclosure features with the addition of sound attenuation material.
- Skid-mounted, steel or aluminum construction with hinged doors. Aluminum enclosures are recommended for high humidity and/or high salt/coastal regions.
- Acoustic insulation that meets UL 94 HF1 flammability classification and repels moisture absorption.
- Steel sound enclosure is designed to 150 mph (241 kph) wind load rating.
- Aluminum sound enclosure is certified to 186 mph (299 kph) wind load rating for 180- 200REZXB/RZXB models.
- Aluminum sound enclosure is certified to 181 mph (291 kph) wind load rating for 250- 400REZXB/RZXB, 450REZXB and 300REZXC models.

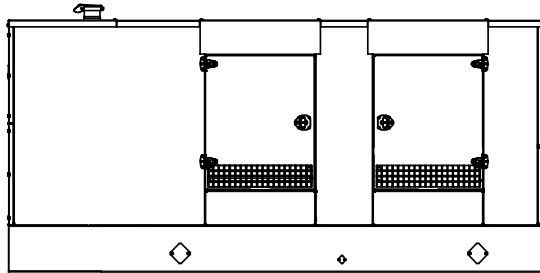

180/200REZXB/RZXB Enclosure

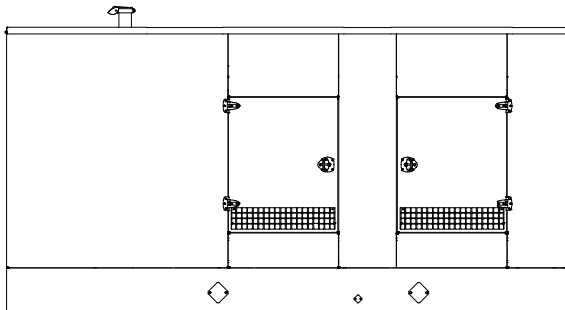

250REZXB/RZXB and 300REZXC Enclosure

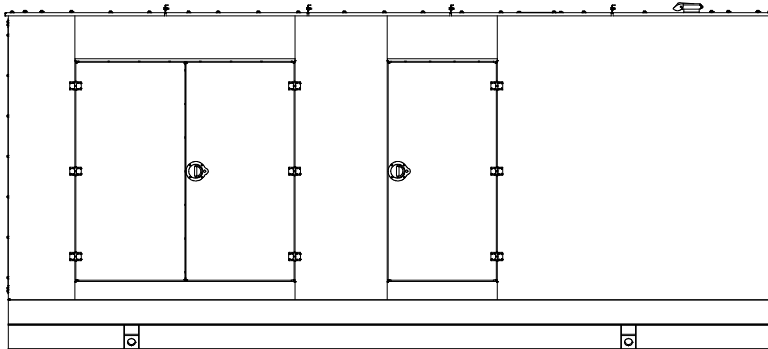

300/350REZXB/RZXB Enclosure

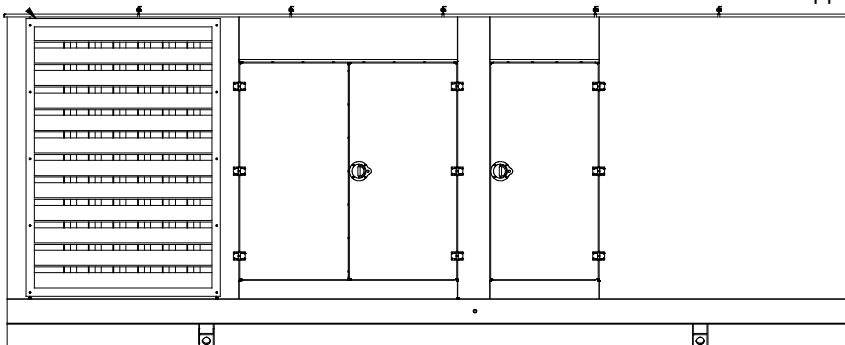

400REZXB/RZXB and 450REZXB Enclosure

Available Approvals and Listings

- UL 2200 Listing
- CSA Certified
- cUL Listing
- IBC Seismic Certification
- Hurricane Rated Enclosure - Available on sound aluminum, 180REZXB- 250REZXB, 350- 450REZXB and 300REZXC models (Impact rated for Large Missile Level E and Wind load rated per Florida Building Code tested to TAS201- 94, TAS202- 94 and TAS203- 94 standards)

NOTE: Some models may have limited third-party approvals; see your local distributor for details.

180-250REZXB/RZXB and 300REZXC Weather and Sound Enclosure

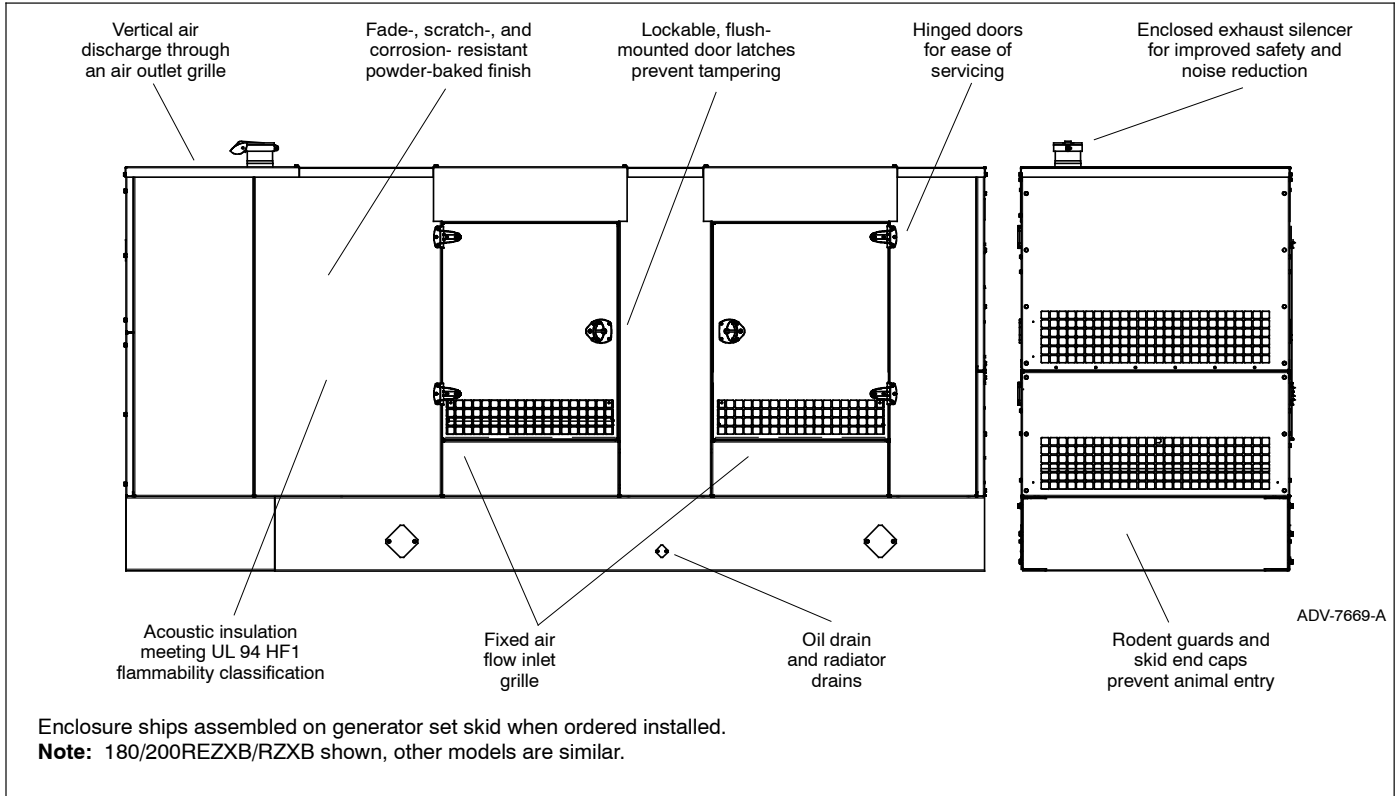

Enclosure Features

- Available in steel formed panel, solid construction. Preassembled package offering corrosion resistant, dent resilient structure mounting directly to skid.
- Power Armor™ automotive-grade finish resulting in advanced corrosion and abrasion protection as well as enhanced edge coverage and color retention.
- Power Armor™ surpasses 3,000-hour salt spray corrosion tests per ASTM B- 1117.
- Internal critical exhaust silencer offering maximum component life and operator safety.
NOTE: Installing an additional length of exhaust tail pipe may increase backpressure levels. Please refer to the generator set spec sheet for the maximum backpressure value.
- Interchangeable modular panel construction. Allows complete serviceability or replacement without compromising enclosure design.
- Cooling/combustion air intake with a horizontal air inlet. Sized for maximum cooling airflow.

- Service access. Multi-personnel doors for easy access to generator set control and servicing of the oil fill and battery.
- Cooling air discharge. Weather protective design featuring a vertical air discharge outlet grille. Redirects cooling air up and above enclosures to reduce noise ambient.

Additional Sound Enclosure Features

- Available in steel or aluminum formed panel, solid construction.
- Attenuated design. Acoustic insulation UL 94 HF1 listed for flame resistance with up to 51 mm (2 in.) thickness.
- Cooling air discharge. The sound enclosures include acoustic insulation with urethane film.

300- 400REZXB/RZXB and 450REZXB Weather and Sound Enclosure Options

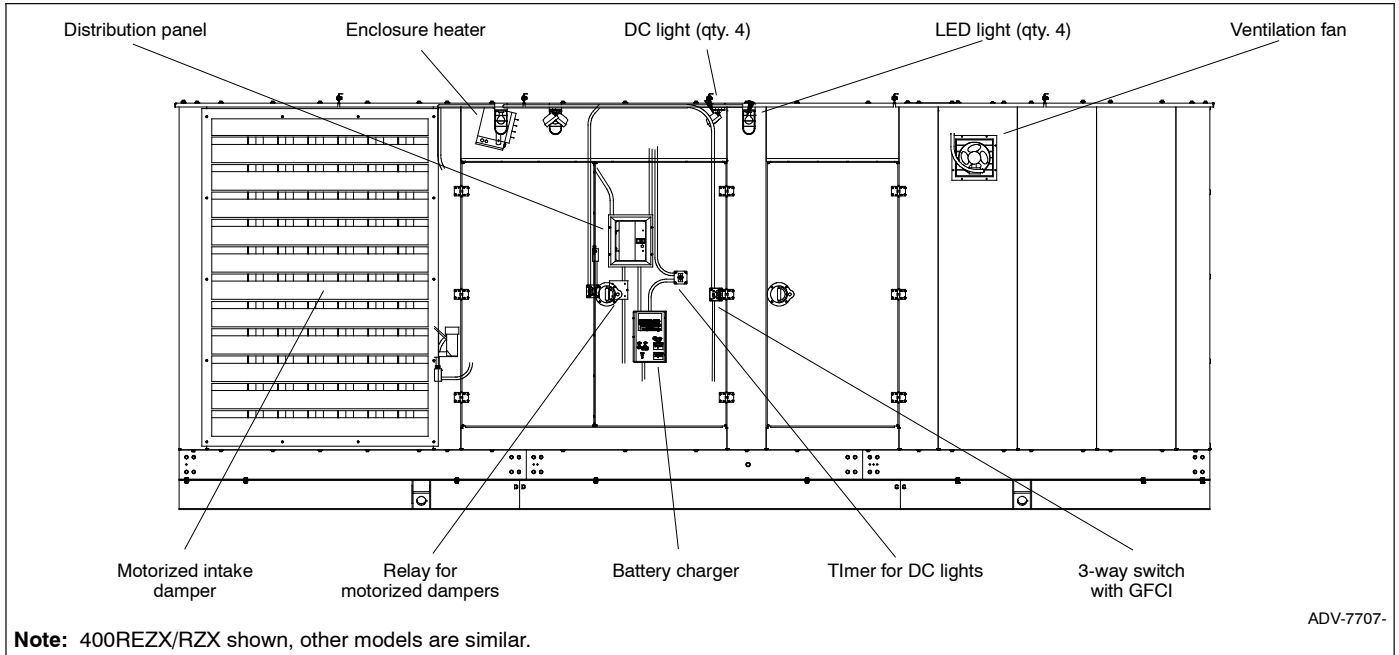

Basic Electrical Package (BEP)

Distribution Panel/Load Center. Prewired AC power distribution of all factory-installed features including block heater, two GFCI-protected internal 120-volt service receptacles, internal lighting, and commercial grade wall switch. The load center is powered by building source power and protected by a main circuit breaker, rated for 100 amps with capacity and circuit positions for future expansion. AC power distribution installed in accordance with NEC and all wiring within EMT thin wall conduit. Four LED lights located within UL-listed fixtures designed for wet locations.

- BEP available with single-phase load center 120/240 VAC.
- BEP available with 3-phase load center 120/208/ 240 VAC.

Enclosure Heater

Heater, 5 kW Ceiling Mounted. Electrical utility heater prewired to load center inside the enclosure. Rated at 17100 Btu includes adjustable louvers offering down flow and horizontal air tuning, built-in thermostat with automatic fan delay controls.

- Heater available in single phase at 240 VAC.
- Heater available in three phase at 208 or 240 VAC.

DC Light Package

- DC Light Package (DLP).** Prewired DC light package offering an economical alternative light source within the enclosure, as a complement to the BEP or a source of light when AC power is not available. Battery drain limited with fuse protection and controlled through a 0- 60 minute, spring-wound, no-hold timer. Available in LED for generator sets between 300- 450 kW.

Miscellaneous Package Options

- Battery Charger, Mounted.** Mounting, prewiring of DC output and AC input when optional BEP is selected. Battery charger located inside the enclosure and accessible through an access door.

Block Heater, Junction Box. Factory-supplied block heater prewired to a junction box providing a convenient location for the customer wiring of the block heater.

- Heater available in single phase at 240 VAC.
- Heater available in three phase at 208 or 240 VAC.

Enclosure Design Options

- Aluminum Enclosure** (available with sound enclosure only)
- Steel Enclosure**
- Panic Bar** for each latching door. Provides additional safety for individuals working on the generator set while in the enclosure.

Motorized Variable Damper and Ventilation

Motorized Air Inlets

- Aluminum construction
- Galvanized steel construction (available with sound enclosure only)

Motorized Air Outlets

- Aluminum construction
- Galvanized steel construction (available with sound enclosure only)
- Ventilation Fan, 22.6 cm/min. (800 cfm) Wall Mount.** Direct drive 3-blade 305 mm (12 in.) aluminum propeller fan with automatic shutters, driven by a totally enclosed air-over motor housed within a corrosion-resistant housing. Remote thermostatically controlled over a temperature range of 27°C to 54°C (80°F to 130°F). All components are prewired and installed.
- Gravity Air Outlet Louver.** Aluminum louvers closed when unit is not running. After the unit starts, the forced cooling air opens the outlet louvers.

Weather and Sound Enclosure Specifications

Model	Max. Dimensions, mm (in.)			Weight, kg (lb.) †			Sound Enclosure, Sound Pressure Level at 60Hz with Full Load, dB(A) *
	Length	Width	Height	Steel Weather Enclosure	Steel Sound Enclosure	Aluminum Sound Enclosure	
180REZXB	4347(171.2)	1386 (54.6)	2164 (85.2)	3177 (7004)	3205 (7066)	2935 (6471)	72
180RZXB	4347(171.2)	1386 (54.6)	2164 (85.2)	3177 (7004)	3205 (7066)	2935 (6471)	74
200REZXB	4347(171.2)	1386 (54.6)	2164 (85.2)	3307 (7291)	3334 (7350)	3064 (6755)	72
200RZXB	4347(171.2)	1386 (54.6)	2164 (85.2)	3307 (7291)	3334 (7350)	3064 (6755)	74
250REZXB	4526(178.2)	1786 (70.3)	2460 (96.9)	3942 (8691)	3969 (8750)	3647 (8040)	70
250RZXB	4526(178.2)	1786 (70.3)	2460 (96.9)	3942 (8691)	3969 (8750)	3647 (8040)	72
300REZXC	4526(178.2)	1786 (70.3)	2460 (96.9)	3942 (8691)	3969 (8750)	3647 (8040)	71
300REZXB	6305(248.2)	2229 (87.8)	2864(112.8)	5805 (12798)	6304 (13898)	5400 (11905)	70
300RZXB	6305(248.2)	2229 (87.8)	2864(112.8)	5805 (12798)	6304 (13898)	5400 (11905)	70
350REZXB	6305(248.2)	2229 (87.8)	2864(112.8)	5805 (12798)	6304 (13898)	5400 (11905)	70
350RZXB	6305(248.2)	2229 (87.8)	2864(112.8)	5805 (12798)	6304 (13898)	5400 (11905)	70
400REZXB	7230(284.6)	2493 (98.2)	2858(112.5)	6497 (14323)	6725 (14826)	6043 (13323)	71
400RZXB	7230(284.6)	2493 (98.2)	2858(112.5)	6497 (14323)	6725 (14826)	6043 (13323)	71
450REZXB	7230(284.6)	2493 (98.2)	2858(112.5)	6497 (14323)	6725 (14826)	6043 (13323)	71

Note: Refer to the respective ADV drawings for details.

* Log average sound pressure level of 8 measured positions around the perimeter of the unit at a distance of 7 m (23 ft). Refer to TIB-114 for details.

† Weight includes the generator set (wet), enclosure, and silencer. The generator set weight represents using the largest alternator option.

DISTRIBUTED BY:

Availability is subject to change without notice. Kohler Co. reserves the right to change the design or specifications without notice and without any obligation or liability whatsoever. Contact your local Kohler® generator set distributor for availability.

© 2009 Kohler Co. All rights reserved.