

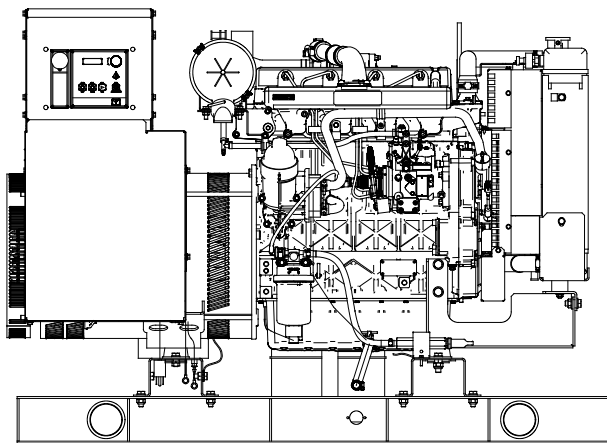

**Tier 4i EPA-Certified for Stationary Emergency Applications**

## Ratings Range

		<b>60 Hz</b>
<b>Standby:</b>	<b>kW</b>	23-31
	<b>kVA</b>	23-39
<b>Prime:</b>	<b>kW</b>	21-28
	<b>kVA</b>	21-35



## Standard Features

- Kohler Co. provides one-source responsibility for the generating system and accessories.
- The generator set and its components are prototype-tested, factory-built, and production-tested.
- The 60 Hz generator set offers a UL 2200 listing.
- The generator set accepts rated load in one step.
- The 60 Hz generator set meets NFPA 110, Level 1, when equipped with the necessary accessories and installed per NFPA standards.
- The generator set engine is certified to meet the Environmental Protection Agency (EPA) emergency stationary emissions requirements.
- A one-year limited warranty covers all generator set systems and components. Two- and five-year extended limited warranties are also available.
- Alternator features:
  - Kohler's wound field excitation system with its unique PowerBoost™ design delivers great voltage response and short-circuit capability.
  - The brushless, rotating-field alternator has broadrange reconnectability.
- Other features:
  - Kohler designed controllers for guaranteed system integration and remote communication. See Controllers on page 3.
  - The low coolant level shutdown prevents overheating (standard on radiator models only).
  - Integral vibration isolation eliminates the need for under-unit vibration spring isolators.

## Generator Set Ratings

Alternator	Voltage	Ph	Hz	130° C Rise Standby Rating		105° C Rise Prime Rating	
				kW/kVA	Amps	kW/kVA	Amps
4D5.6	120/208	3	60	29/36	101	26/33	90
	127/220	3	60	29/36	95	26/33	85
	120/240	3	60	29/36	87	26/33	78
	120/240	1	60	23/23	96	21/21	88
	139/240	3	60	29/36	87	26/33	78
	220/380	3	60	27/34	51	25/31	47
	277/480	3	60	29/36	44	26/33	39
	347/600	3	60	29/36	35	26/33	31
4D8.3	120/208	3	60	31/39	108	28/35	97
	127/220	3	60	31/39	102	28/35	92
	120/240	3	60	31/39	93	28/35	84
	120/240	1	60	29/29	121	26/26	108
	139/240	3	60	31/39	93	28/35	84
	220/380	3	60	31/39	59	28/35	53
	277/480	3	60	31/39	47	28/35	42
	347/600	3	60	31/39	37	28/35	34
4E5.6	120/240	1	60	29/29	121	26/26	108
4E8.3	120/240	1	60	31/31	129	27/27	113

**RATINGS:** All three-phase units are rated at 0.8 power factor. All single-phase units are rated at 1.0 power factor. *Standby Ratings:* Standby rating is applicable to varying loads for the duration of a power outage. There is no overload capability for this rating. *Prime Power Ratings:* At varying load, the number of generator set operating hours is unlimited. A 10% overload capacity is available for one hour in twelve. Ratings are in accordance with ISO-8528-1 and ISO-3046-1. For limited running time and continuous ratings, consult the factory. Obtain the technical information bulletin (TIB-101) for ratings guidelines, complete ratings definitions, and site condition derates. The generator set manufacturer reserves the right to change the design or specifications without notice and without any obligation or liability whatsoever.

# Alternator Specifications

Specifications	Alternator
Manufacturer	Kohler
Type	4-Pole, Rotating-Field
Exciter type	Brushless, Wound Field
Leads: quantity, type	12, Reconnectable 4, 110-120/220-240
Voltage regulator	Solid State, Volts/Hz
Insulation:	NEMA MG1
Material	Class H
Temperature rise	130°C, Standby
Bearing: quantity, type	1, Sealed
Coupling	Flexible Disc
Amortisseur windings	Full
Voltage regulation, no-load to full-load	Controller Dependent
One-step load acceptance	100% of Rating
Unbalanced load capability	100% of Rated Standby Current

- NEMA MG1, IEEE, and ANSI standards compliance for temperature rise and motor starting.
- Sustained short-circuit current of up to 300% of the rated current for up to 10 seconds.
- Sustained short-circuit current enabling downstream circuit breakers to trip without collapsing the alternator field.
- Self-ventilated and dripproof construction.
- Windings are vacuum-impregnated with epoxy varnish for dependability and long life.
- Superior voltage waveform from a two-thirds pitch stator and skewed rotor.

Specifications	Alternator
Peak motor starting kVA:	(35% dip for voltages below)
480 V 4D5.6 (12 lead)	75
480 V 4D8.3 (12 lead)	120
240 V 4E5.6 (4 lead)	44
240 V 4E8.3 (4 lead)	74

## Application Data

### Engine

Engine Specifications	
Manufacturer	Kohler Diesel
Engine model	KDI2504TM
Engine type	4-Cycle, Turbocharged
Cylinder arrangement	4 Inline
Displacement, L (cu. in.)	2.5 (158)
Bore and stroke, mm (in.)	88 x 102 (3.46 x 4.02)
Compression ratio	18:1
Piston speed, m/min. (ft./min.)	367 (1206)
Main bearings: quantity, type	5, Sleeve
Rated rpm	1800
Max. power at rated rpm, kWm (BHP)	36.4 (48.8)
Cylinder head material	Cast Iron
Crankshaft material	Cast Iron
Valve material:	
Intake	Stainless Steel
Exhaust	Stainless Steel
Governor: type, make/model	Stanadyne/Mechanical (or Electronic *)
	Droop, 5% (or Isochronous *)
Frequency regulation, no-load to full-load	±0.5%
Frequency regulation, steady state	Fixed
Frequency	Fixed
Air cleaner type, all models	Dry

\* Requires available electronic governor option

### Engine Electrical

Engine Electrical System	
Battery charging alternator:	
Ground (negative/positive)	Negative
Volts (DC)	12
Ampere rating	50
Starter motor rated voltage (DC)	12
Battery, recommended cold cranking amps (CCA):	
Quantity, CCA rating	One, 650
Battery voltage (DC)	12

### Fuel

Fuel System	
Fuel supply line, min. ID, mm (in.)	8.0 (0.31)
Fuel return line, min. ID, mm (in.)	6.0 (0.25)
Max. lift, engine-driven fuel pump, m (ft.)	3.0 (10.0)
Max. fuel flow, Lph (gph)	46 (12.2)
Max. return line restriction, kPa (in. Hg)	20 (5.9)
Fuel filter	
Prefilter	74 Microns
Primary/Water Separator	5 Microns @ 98% Efficiency
Recommended fuel	#2 Ultra Low Sulfur Diesel

### Lubrication

Lubricating System	
Type	Full Pressure
Oil pan capacity, L (qt.)	10.7 (11.3)
Oil pan capacity with filter, L (qt.)	11 (11.6)
Oil filter: quantity, type	1, Cartridge
Oil cooler	—

### Exhaust

Exhaust System	
Exhaust manifold type	Dry
Exhaust flow at rated kW, m <sup>3</sup> /min. (cfm)	7.8 (275)
Exhaust temperature at rated kW, dry exhaust, °C (°F)	543 (1009)
Maximum allowable back pressure, kPa (in. Hg)	8 (2.4)
Exhaust outlet size at engine hookup, mm (in.)	50.8 (2)

## Application Data

### Cooling

#### Radiator System

Ambient temperature, °C (°F) *	50 (122)
Engine jacket water capacity, L (gal.)	4.4 (1.6)
Radiator system capacity, including engine, L (gal.)	11.4 (3)
Engine jacket water flow, Lpm (gpm)	59.0 (15.6)
Heat rejected to cooling water at rated kW, dry exhaust, kW (Btu/min.)	27.0 (1536)
Water pump type	Centrifugal
Fan diameter, including blades, mm (in.)	406 (16.0)
Fan, kWm (HP)	0.6 (0.8)
Max. restriction of cooling air, intake and discharge side of radiator, kPa (in. H <sub>2</sub> O)	0.125 (0.5)

\* Enclosure reduces ambient temperature capability by 5°C (9°F).

### Operation Requirements

#### Air Requirements

Radiator-cooled cooling air, m <sup>3</sup> /min. (scfm) †	53.8 (1900)
Combustion air, m <sup>3</sup> /min. (cfm)	2.7 (96.9)
Heat rejected to ambient air:	
Engine, kW (Btu/min.)	10.3 (587)
Alternator, kW (Btu/min.)	6.7 (381)
Max. air intake restriction, kPa (in. Hg)	3.0 (0.89)

† Air density = 1.20 kg/m<sup>3</sup> (0.075 lbm/ft<sup>3</sup>)

#### Fuel Consumption

Diesel, Lph (gph) at % load	Standby Rating
100%	9.8 (2.6)
75%	7.9 (2.1)
50%	5.7 (1.5)
25%	3.4 (0.9)
Diesel, Lph (gph) at % load	Prime Rating
100%	9.1 (2.4)
75%	7.2 (1.9)
50%	5.3 (1.4)
25%	3.0 (0.8)

## Controller

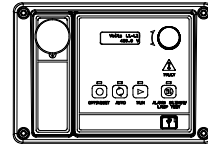

#### Decision-Maker® 3000 Controller

Provides advanced control, system monitoring, and system diagnostics for optimum performance and compatibility.

- Digital display and menu control provide easy local data access
- Measurements are selectable in metric or English units
- Remote communication thru a PC via network or serial configuration
- Controller supports Modbus® protocol
- Integrated hybrid voltage regulator with ±0.5% regulation
- Built-in alternator thermal overload protection
- NFPA 110 Level 1 capability

Refer to G6-100 for additional controller features and accessories.

Modbus® is a registered trademark of Schneider Electric.

## Additional Standard Features

- Air Cleaner, Heavy Duty
- Alternator Protection
- Battery Rack and Cables
- Closed Crankcase Ventilation
- Oil Drain and Coolant Drain with Hose Barb
- Oil Drain Extension (with enclosure models only)
- Operation and Installation Literature
- Stainless Steel Fasteners on Enclosure (with enclosure models only)
- Rodent Guards

## Available Options

### Approvals and Listings

- CSA Certified
- IBC Seismic Certification
- UL2200 Listing

### Enclosed Unit

- Sound Enclosure (with enclosed critical silencer)
- Weather Enclosure (with enclosed critical silencer)
- Stainless Steel Latches and Hinges

### Open Unit

- Exhaust Silencer, Critical (kit: PA-352663)
- Flexible Exhaust Connector, Stainless Steel

### Fuel System

- Flexible Fuel Lines
- Fuel Pressure Gauge
- Subbase Fuel Tanks

### Controller

- Common Failure Relay
- Input/Output Module
- Manual Speed Adjust (requires Electronic Governor)
- Remote Annunciator Panel
- Remote Emergency Stop
- Run Relay

### Cooling System

- Block Heater (700 W, 110-120 V)  
Recommended for ambient temperatures below 0°C (32°F).
- Radiator Duct Flange

### Electrical System

- Alternator Strip Heater
- Battery
- Battery Charger, Equalize/Float Type
- Battery Heater
- Electronic Governor
- Line Circuit Breaker (NEMA type 1 enclosure)
- Line Circuit Breaker with Shunt Trip (NEMA type 1 enclosure)

### Miscellaneous

- Air Cleaner Restriction Indicator
- Engine Fluids Added
- Rated Power Factor Testing

### Literature

- General Maintenance
- NFPA 110
- Overhaul
- Production

### Warranty

- 2-Year Basic Limited Warranty
- 5-Year Basic Limited Warranty
- 5-Year Comprehensive Limited Warranty

### Other Options

- \_\_\_\_\_
- \_\_\_\_\_
- \_\_\_\_\_
- \_\_\_\_\_
- \_\_\_\_\_

## Dimensions and Weights

Overall Size, L x W x H, mm (in.):

Open Unit Skid: 1400 x 813 x 1024 (55.1 x 32.0 x 40.3)

Enclosure Skid: 1938 x 813 x 1174 (76.5 x 32.0 x 47.0)

Weight (radiator model), wet, kg (lb.): 512 (1130)

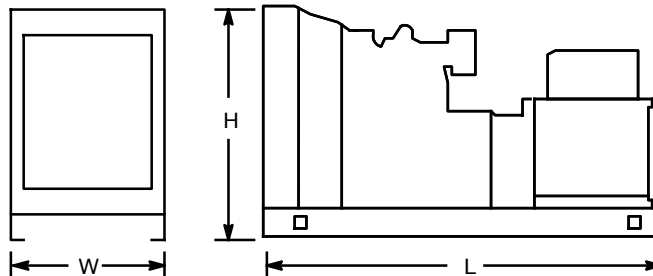

NOTE: This drawing is provided for reference only and should not be used for planning installation. Contact your local distributor for more detailed information.

**DISTRIBUTED BY:**