

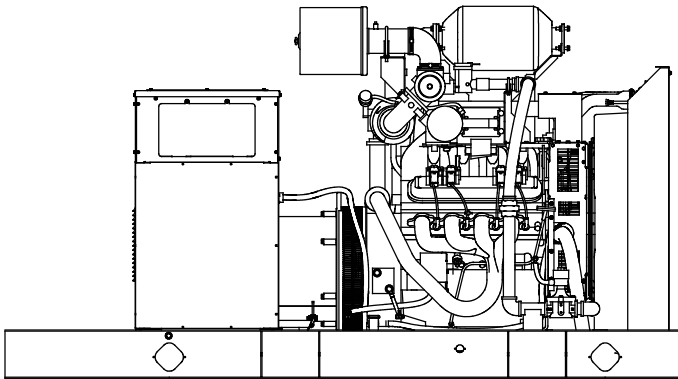

**EPA-Certified for Stationary
Emergency Applications**

Ratings Range

Standby:	kW	60 Hz
	kVA	91-156



Standard Features

- Kohler Co. provides one-source responsibility for the generating system and accessories.
- The generator set and its components are prototype-tested, factory-built, and production-tested.
- The 60 Hz generator set offers a UL 2200 listing.
- At 60 Hz, the generator set accepts rated load in one step.
- The 60 Hz generator set meets NFPA 110, Level 1, when equipped with the necessary accessories and installed per NFPA standards.
- A one-year limited warranty covers all generator set systems and components. Two- and five-year extended limited warranties are also available.
- Alternator features:
 - The unique Fast-Response® X excitation system delivers excellent voltage response and short-circuit capability using a rare-earth, permanent magnet (PM)-excited alternator.
 - The brushless, rotating-field alternator has broadrange reconnectability.
- Other features:
 - Kohler designed controllers for one-source system integration and remote communication. See Controllers on page 3.
 - The electronic, isochronous governor incorporates an integrated drive-by-wire throttle body actuator delivering precise frequency regulation.

Generator Set Ratings

Alternator	Voltage	Ph	Hz	Natural Gas 130°C Rise Standby Rating		LP Gas 130°C Rise Standby Rating	
				kW/kVA	Amps	kW/kVA	Amps
4R12X	120/208	3	60	124/155	430	105/131	364
	127/220	3	60	125/156	410	105/131	344
	120/240	3	60	124/155	373	105/131	316
	120/240	1	60	91/91	379	91/91	379
	139/240	3	60	125/156	376	105/131	316
	220/380	3	60	112/140	213	105/131	199
	277/480	3	60	125/156	188	105/131	158
	347/600	3	60	125/156	150	105/131	126
4R13X	120/208	3	60	125/156	434	106/133	368
	127/220	3	60	125/156	410	106/133	348
	120/240	3	60	125/156	376	106/133	319
	120/240	1	60	107/107	446	100/100	417
	139/240	3	60	125/156	376	106/133	319
	220/380	3	60	124/155	235	106/133	201
	277/480	3	60	125/156	188	106/133	159
347/600	3	60	125/156	150	106/133	128	
4T13X	120/240	1	60	125/125	521	105/105	438

RATINGS: All three-phase units are rated at 0.8 power factor. All single-phase units are rated at 1.0 power factor. **Standby Ratings:** The standby rating is applicable to varying loads for the duration of a power outage. There is no overload capability for this rating. **Prime Power Ratings:** At varying load, the number of generator set operating hours is unlimited. A 10% overload capacity is available for one hour in twelve. Ratings are in accordance with ISO-8528-1 and ISO-3046-1. For limited running time and continuous ratings, consult the factory. Obtain technical information bulletin (TIB-101) for ratings guidelines, complete ratings definitions, and site condition derates. The generator set manufacturer reserves the right to change the design or specifications without notice and without any obligation or liability whatsoever. For dual fuel engines, use the LP gas ratings for both the primary and secondary fuels.

Alternator Specifications

Specifications	Alternator
Manufacturer	Kohler
Type	4-Pole, Rotating-Field
Exciter type	Brushless, Rare-Earth Permanent Magnet
Leads: quantity, type	
4RX	12, Reconnectable
4TX	4, 110-120/220-240 V
Voltage regulator	Solid State, Volts/Hz
Insulation:	NEMA MG1
Material	Class H
Temperature rise	130°C, Standby
Bearing: quantity, type	1, Sealed
Coupling	Flexible Disc
Amortisseur windings	Full
Voltage regulation, no-load to full-load	Controller Dependent
One-step load acceptance	100% of Rating
Unbalanced load capability	100% of Rated Standby Current
Peak motor starting kVA:	(35% dip for voltages below)
480 V 4R12X (12 lead)	448 (60 Hz)
480 V 4R13X (12 lead)	540 (60 Hz)
240 V 4T13X (4 lead)	440 (60 Hz)

- NEMA MG1, IEEE, and ANSI standards compliance for temperature rise and motor starting.
- Sustained short-circuit current of up to 300% of the rated current for up to 10 seconds.
- Sustained short-circuit current enabling downstream circuit breakers to trip without collapsing the alternator field.
- Self-ventilated and dripproof construction.
- Windings are vacuum-impregnated with epoxy varnish for dependability and long life.
- Superior voltage waveform from a two-thirds pitch stator and skewed rotor.

Application Data

Engine

Engine Specifications	
Manufacturer	PSI
Engine: model, type	Industrial 8.8 L, 4-Cycle, Turbocharged
Cylinder arrangement	V-8
Displacement, L (cu. in.)	8.8 (537)
Bore and stroke, mm (in.)	110 x 114 (4.35 x 4.5)
Compression ratio	10.1:1
Piston speed, m/min. (ft./min.)	411 (1350)
Main bearings: quantity, type	5, Bi-Metal Steel and Aluminum
Rated rpm	1800
Max. power at rated rpm (NG), kW (HP)	142 (190)
Max. power at rated rpm, (LPG) kW (HP)	121 (162)
Cylinder head material	Cast Iron
Piston type and material	Flat Top, Hypereutectic Cast Alum.
Crankshaft material	Forged Steel, Induction Hardened, Tangential Fillet
Valve (exhaust) material	Int.-A193 Exh. Inconel
Governor type	Electronic
Frequency regulation, no-load to full-load	Isochronous
Frequency regulation, steady state	±0.5%
Frequency	Fixed
Air cleaner type, all models	Dry

Exhaust

Exhaust System	
Exhaust manifold type	Dry
Exhaust flow at rated kW, m ³ /min. (cfm)	21.1 (745)
Exhaust temperature at rated kW, dry exhaust, °C (°F)	649 (1200)
Maximum allowable back pressure, kPa (in. Hg)	10.2 (3.0)
Exhaust outlet size at engine hookup, mm (in.)	Flanged Outlet at Cataly see ADV drawing

Engine Electrical

Engine Electrical System	
Ignition system	Individual Coil Near Plug Ignition
Battery charging alternator:	
Ground (negative/positive)	Negative
Volts (DC)	12
Ampere rating	70
Starter motor rated voltage (DC)	12
Battery, recommended cold cranking amps (CCA):	
Qty., rating for -18°C (0°F)	1, 630
Battery voltage (DC)	12

Fuel

Fuel System	
Fuel type	Natural Gas, LP Gas, or Dual Fuel
Fuel supply line inlet	1.5 NPTF
Natural gas fuel supply pressure, kPa (in. H ₂ O)	1.74-2.74 (7-11)
LPG vapor withdrawal fuel supply pressure, kPa (in. H ₂ O)	1.24-2.74 (5-11)
Dual fuel engine, LPG vapor withdrawal fuel supply pressure, kPa (in. H ₂ O)	1.24 (5)

Fuel Composition Limits *	Nat. Gas	LP Gas
Methane, % by volume	90 min.	1.2 max.
Ethane, % by volume	4.0 max.	10 max.
Propane, % by volume	1.0 max.	96 max.
Propene, % by volume	0.1 max.	3 max.
C ₄ and higher, % by volume	0.3 max.	3 max.
Sulfur, ppm mass		25 max.
Lower heating value, MJ/m ³ (Btu/ft ³), min.	33.2 (890)	78.8 (2116)

* Fuels with other compositions may be acceptable. If your fuel is outside the listed specifications, contact your local distributor for further analysis and advice.

Application Data

Lubrication

Lubricating System

Type	Full Pressure
Oil pan capacity, L (qt.) §	8.0 (8.5)
Oil pan capacity with filter, L (qt.) §	8.5 (9.0)
Oil filter: quantity, type §	1, Cartridge
§ Kohler recommends the use of Kohler Genuine oil and filters.	

Cooling

Radiator System

Ambient temperature, °C (°F) *	50 (122)
Engine jacket water capacity, L (gal.)	13.4 (3.54)
Radiator system capacity, including engine, L (gal.)	27.6 (7.3)
Engine jacket water flow, Lpm (gpm)	125 (33)
Heat rejected to cooling water at rated kW, dry exhaust, kW (Btu/min.)	73.5 (4184)
Heat rejected to engine oil at rated kW, kW (Btu/min.)	1.2 (67.5)
Water pump type	Centrifugal
Fan diameter, including blades, mm (in.)	660 (26.0)
Fan, kWm (HP)	8.9 (12.0)
Max. restriction of cooling air, intake and discharge side of radiator, kPa (in. H ₂ O)	0.125 (0.5)

* Enclosure with enclosed silencer reduces ambient temperature capability by 5°C (9°F).

Operation Requirements

Air Requirements

Radiator-cooled cooling air, m ³ /min. (scfm) †	306 (10800)
Combustion air, m ³ /min. (cfm)	6.9 (244)
Heat rejected to ambient air:	
Engine, kW (Btu/min.)	21.6 (1230)
Alternator, kW (Btu/min.)	15.7 (893)

† Air density = 1.20 kg/m³ (0.075 lbm/ft³)

Fuel Consumption ‡

Natural Gas, m ³ /hr. (cfh) at % load	Standby Ratings
100%	42.8 (1511)
75%	34.1 (1204)
50%	25.2 (890)
25%	16.5 (583)
0%	6.8 (240)

LP Gas, m ³ /hr. (cfh) at % load	Standby Ratings
100%	17.7 (626)
75%	13.4 (473)
50%	9.5 (334)
25%	5.9 (209)
0%	2.7 (95)

‡ Nominal fuel rating: Natural gas, 37 MJ/m³ (1000 Btu/ft.³)
LP vapor, 93 MJ/m³ (2500 Btu/ft.³)

LP vapor conversion factors:

- 8.58 ft.³ = 1 lb.
- 0.535 m³ = 1 kg.
- 36.39 ft.³ = 1 gal.

Controllers

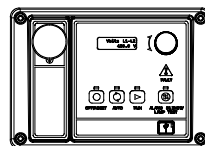

APM402 Controller

Provides advanced control, system monitoring, and system diagnostics for optimum performance and compatibility.

- Digital display and menu control provide easy local data access
 - Measurements are selectable in metric or English units
 - Remote communication thru a PC via network or serial configuration
 - Controller supports Modbus® protocol
 - Integrated hybrid voltage regulator with ±0.5% regulation
 - Built-in alternator thermal overload protection
 - NFPA 110 Level 1 capability
- Refer to G6-161 for additional controller features and accessories.

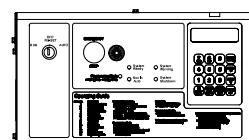

Decision-Maker® 550 Controller

Provides advanced control, system monitoring, and system diagnostics with remote monitoring capabilities.

- Digital display and keypad provide easy local data access
- Measurements are selectable in metric or English units
- Remote communication thru a PC via network or modem configuration
- Controller supports Modbus® protocol
- Integrated voltage regulator with ±0.25% regulation
- Built-in alternator thermal overload protection
- NFPA 110 Level 1 capability

Refer to G6-46 for additional controller features and accessories.

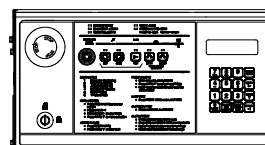

Decision-Maker® 6000 Paralleling Controller

Provides advanced control, system monitoring, and system diagnostics with remote monitoring capabilities for paralleling multiple generator sets.

- Paralleling capability with first-on logic, synchronizer, kW and kVAR load sharing, and protective relays
- Digital display and keypad provide easy local data access
- Measurements are selectable in metric or English units
- Remote communication thru a PC via network or modem configuration
- Controller supports Modbus® protocol
- Integrated voltage regulator with ±0.25% regulation
- Built-in alternator thermal overload protection
- NFPA 110 Level 1 capability

Refer to G6-107 for additional controller features and accessories.

Modbus® is a registered trademark of Schneider Electric.

Standard Features

- Alternator Protection
- Battery Rack and Cables
- Closed Crankcase Ventilation (CCV) Filters
- Customer Connection
(Standard with Decision-Maker® 6000 controller only)
- Electronic, Isochronous Governor
- Gas Fuel System (includes fuel mixer, electronic secondary gas regulator, gas solenoid valve, and flexible fuel line between the engine and the skid-mounted fuel system components)
- Integral Vibration Isolation
- Local Emergency Stop Switch
- Oil Drain Extension
- Operation and Installation Literature
- Three-Way Exhaust Catalyst

Available Options

Approvals and Listings

- CSA Certified
- IBC Seismic Certification
- UL 2200 Listing
- Hurricane Rated Enclosure

Enclosed Unit

- Sound Enclosure (with enclosed critical silencer)
- Weather Enclosure (with enclosed critical silencer)

Open Unit

- Exhaust Silencer, Critical (kit: PA-324470)
- Flexible Exhaust Connector, Stainless Steel

Fuel System

- Dual Fuel NG/LPG (automatic changeover)
- Flexible Fuel Line
(required when the generator set skid is spring mounted)
- Gas Filter
- LP Liquid Withdrawal (vaporizer)
- Secondary Gas Solenoid Valve

Controller

- Common Fault Relay
- Communication Products and PC Software
- Customer Connection
(Decision-Maker® 550 and 6000 controllers only)
- Dry Contact (isolated alarm)
(Decision-Maker® 550 and 6000 controllers only)
- Two Input/Five Output Module (APM402 controller only)
- Remote Annunciator Panel
- Remote Audiovisual Alarm Panel
(Decision-Maker® 550 and 6000 controllers only)
- Remote Emergency Stop
- Run Relay

Cooling System

- Block Heater, 1800 W, 110-120 V
- Block Heater, 2000 W, 190-240 V
Required for ambient temperatures below 10°C (50°F)
- Block Heater, 2000 W, 120 V
(Only available with LP liquid withdrawal)
- Radiator Duct Flange

Electrical System

- Alternator Strip Heater
- Battery
- Battery Charger, Equalize/Float Type
- Battery Heater
- Line Circuit Breaker (NEMA1 enclosure)
- Line Circuit Breaker with Shunt Trip (NEMA1 enclosure)

Miscellaneous

- Air Cleaner Restrictor Indicator
- Certified Test Report
- Crankcase Ventilation Heater
Recommended for ambient temperatures below 0°C (32°F)
- Engine Fluids Added
- Rated Power Factor Testing
- Rodent Guards

Literature

- General Maintenance
- NFPA 110
- Overhaul
- Production

Warranty

- 2-Year Basic Limited Warranty
- 5-Year Basic Limited Warranty
- 5-Year Comprehensive Limited Warranty

Other Options

- _____
- _____
- _____
- _____
- _____
- _____
- _____

Dimensions and Weights

Overall Size, L x W x H, mm (in.):

Wide Skid 2800 x 1120 x 1538 (110.2 x 44.1 x 60.6)

Narrow Skid 2400 x 864 x 1538 (94.5 x 34.0 x 60.6)

Weight (radiator model), wet, kg (lb.): 1365 (3009)

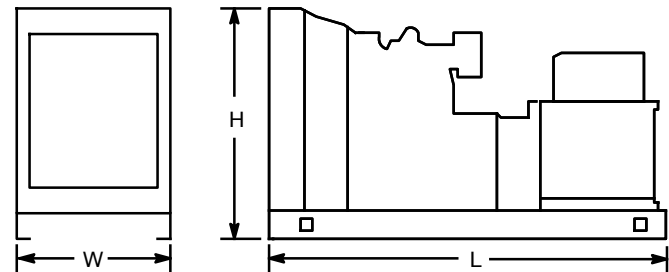

NOTE: This drawing is provided for reference only and should not be used for planning installation. Contact your local distributor for more detailed information.

DISTRIBUTED BY: